

APSX-PIM USER MANUAL

Full-Automatic Electric Desktop Plastic Injection Machine



APSX-PIM User Manual v1.9

ADVANCED PRODUCTION SYSTEMS

APSX, LLC.

© APSX, LLC.
11144 Luschek Dr
Blue Ash, OH 45241
www.apsx.com • info@apsx.com

This equipment manual is intended to provide information for safe operation and maintenance. APSX reserves the right to make changes to equipment in an effort to continually improve the equipment, features, and/or performance. These changes may result in different and/or additional safety measures that are communicated to customers through bulletins as changes occur.

This document contains information which is the exclusive property of APSX LLC. Except for any rights expressly granted by contract, no further publication or commercial use may be made of this document, in whole or in part, without the prior written permission of APSX LLC.

Notwithstanding the foregoing, APSX LLC grants permission to its customers to reproduce this document for limited internal use only.

Copyright © 2019, APSX LLC.
All Rights Reserved.



General Information

Phone Support Number: 1-513-716-5992 (9AM-5PM EST Weekdays)
For non-emergency questions you may also email to support@apsx.com

Please refer to www.apsx.com for the office locations.

Product Upgrades

Upgrades may be available that can improve your equipment. To see what upgrades are available for your machine please visit www.apsx.com or call support number.

Spare Parts

All spare parts for APSX-PIM can be ordered online at www.apsx.com.

Unauthorized Modifications

Under no circumstances should any changes or modifications be made to the electrical circuits, mechanical structures, or the safety devices to the machine and guarding on the mold without the prior, written permission of APSX LLC.



Table of Contents

Injection Molding Process	1
Processing Characteristics	1
Example for Polypropylene	1
Some Terms for Injection Molding.....	2
Safety Precautions	8
Thermal effects:	8
Off-Gases Ventilation:	8
Slipping Hazards:	8
Physical Hazards:	9
Electrical Hazards:	9
Other Safeguards:.....	9
APSX-PIM Injection Molding Machine	11
Plasticizing Section	12
Pre-Plasticizing Section	12
Injection Section.....	12
Injection Valve Section.....	12
Clamping Section.....	12
User Interface Section.....	12
Moving the APSX-PIM to Another Location	13
APSX-PIM Injection Molding Process.....	14
Preparing the Machine	14
Powering the Machine.....	14
System ON.....	14
Installing the Mold	14
APSX-PIM MAGNETS, SWITCHES AND SENSORS:	22
APSX-PIM CYCLE:	23
Settings	24
APSX-PIM User Screen	24
Filling the Hopper	30
Start the Heat.....	30
Manually Controlling.....	30
Purging.....	30
Start RUN.....	31
Stopping the Machine	31
Cleaning the Machine	31
Troubleshooting Guide	32
Machine Specs.....	34



KEY FEATURES OF APSX-PIM.....	34
TECHNICAL OVERVIEW	34
DESIGN ELEMENTS	35
SUPPORT.....	37
SPARE PARTS.....	37
LIMITED WARRANTY	37
TRANSFERABILITY	38
TOOLS AND ACCESSORIES.....	39
Kill-A-Watt.....	39
15/16" Wrench	39
7/16", 1/2", 3/4" Wrenches	40
3/16", 1/4" and M4 Hex Keys	40



Injection Molding Process

It is a science but is also kind of art.

The injection molding of thermoplastic resins is a well-known and widely practiced application. It constitutes a major processing technique for converting plastics into a variety of end-use products. Basically, the process involves heating the solid pellets to melt, then transferring it to a mold and holding it under pressure until it freezes, or solidifies.

Plastic molding compounds represent a range of chemical types. Each type has its own specific processing characteristics which must be considered and understood before it can be successfully molded.

Processing Characteristics

The physical and chemical properties of a plastic dictate the way in which it must be molded. Among these are:

- Melting or softening temperature
- Energy content (specific heat and latent heat)
- Melt viscosity
- Stability and behavior at melt temperatures
- Freezing rate, crystallization rate, and cycle time
- Shrinkage



Example for Polypropylene

For example the PP which is a frequently used plastic has physical, mechanical, impact and thermal properties listed. Specific gravity, mass flow rate, tensile strength, izod impact and deflection temperature under load are some of the properties that make a difference when processing for injection molding.

Some Terms for Injection Molding

Alloy: A term used in the plastics industry to denote blends of polymers or copolymers with other polymers or elastomers. - i.e. ABS/Polycarbonate.

Ambient Temperature: The temperature of a medium surrounding an object. The term is often used to denote prevailing room temperature.

ANSI: Abbreviation for American National Standards Institute.

ASTM: Abbreviation for American Society for Testing and Materials.

Back Pressure: The resistance of the molten plastic material to forward flow. In molding, back pressure increases the temperature of the melt, and contributes to better mixing of colors and homogeneity of the material. However, as back pressure increases, so does cycle time.

Barrel: The section of a molding machine that contains the feed screw, also the section where resin heating and mixing occurs.

Blushing: The tendency of a plastic article to turn white or chalky in areas that are highly stressed.

Bubbles: Air or gas pockets that have formed in the material of the component. Bubbles may vary in size.

Burned: Showing evidence of excessive heating during processing or use of a plastic, as evidenced by blistering, discoloration, distortion or destruction of the surface.

Cavity: A depression, or a set of matching depressions, in a plastics-forming mold which forms the outer surfaces of the molded articles.

Charge: The amount of material used to load a mold at one time or during one cycle.

Clamp: The part of an injection molding machine incorporating the platens that provides the force necessary to hold the mold closed during injection of the molten resin and open the mold to eject the molded part.

Clamping Area: The largest rated molding area an injection press can hold closed under full molding pressure.

Clamping Force: The force applied to the mold to keep it closed, in opposition to the fluid pressure of the compressed molding material within the mold cavity and the runner system.

Clamping Plate: A plate fitted to a mold and used to fasten the mold to a platen.

Clamping Pressure: The pressure applied to the mold to keep it closed during the molding cycle.

Closed-loop Control: System for monitoring and automatically adjusting injection molding process conditions such as temperature, pressure and time. The automatic changes keep part production within preset tolerances.

Cold Flow Lines: Imperfections within the part wall due to thickening or solidification of resin prior to full cavity fill.

Compression Molding: A method of molding in which the molding material, generally preheated, is placed in an open heated mold cavity, the mold is closed with a top force, pressure is applied to force the material into contact with all mold areas.

Conversions (Commonly Used in Injection Molding)

$\text{MPa} \times 145 = \text{psi}$

$^{\circ}\text{C} \times 1.8 + 32 = ^{\circ}\text{F}$

$\text{Liters/min} \times 0.2642 = \text{Gal/min}$

$\text{Inches} \times 25.4 = \text{mm}$

$\text{Flow rate} = ((\# \text{ of cavities}) \times (\text{volume per cavity})) / (\text{injection time})$

Cooling Channels: Channels located within the body of a mold through which a cooling medium is circulated to control the mold surface temperature.

Cooling time: the elapsed time required for the melt to reach its Vicat softening temperature.

Core: A protrusion, or set of matching protrusions, in a plastics forming mold which forms the inner surfaces of the molded articles.

Creep: Due to its viscoelastic nature, a plastic subjected to a load for a period of time tends to deform more than it would from the same load released immediately after application, and the degree of this deformation is dependent of the load duration.

CSA: Abbreviation for the Canadian Standards Association.

Cure Cycle: The time periods at defined conditions to which a reacting thermosetting material is processed to reach a desired property level.

Cure: The process of changing properties of polymer into a more stable and usable condition. This is accomplished by the use of heat, radiation, or reaction with chemical additives.

Custom Molder: A firm specializing in the molding of items or components to the specifications of another firm which handles the sale or distribution of the item, or incorporates the custom molded components in one of its own products.

Cycle Time: The time required by an injection molding system to mold a part and return to its original position/state.

Cycle: complete, repeating sequence of operations for injection molding a part.

Deflection Temperature: The measurement of temperature at which a specimen deflects to a set point under a defined load.

Degassing: The momentary opening and closing of a mold during the early stages of the cycle to permit the escape of air or gas from the heated compound.

Differential Cooling: occurs when one area of the part cools at a different rate or when the mold surfaces are at different temperatures. Warping can result from differential cooling.

Draft: A Slight taper in a mold wall designed to facilitate removal of the molded object from the mold.

Drag Marks: A form of deep scratch or scratches on the surface of the component usually caused by the ejection of the part.

Drooling: The extrusion or leakage of molten resin from nozzle or nozzle sprue bushing area while filling or shooting the mold.

Dwell: A pause in the applied pressure to a mold during the injection cycle just before the mold is completely closed. This dwell allows any gases formed or present to escape from the molding material.

Ejection Pin Marks: A residual mark on the part caused by the profile of the ejection pin.

Ejection Pin: A rod, pin or sleeve that pushes a molded part off of a core or out of a cavity of a mold.

Ejector Rod: A bar that actuates the ejector assembly when the mold opens.

Family mold: A mold that produces non-identical parts simultaneously from multiple cavities.

Fill pressure: the injection pressure required to fill the cavity.

Fill Time (also known as Injection): Time required to fill the cavity or mold.

Fill: The packing of the cavity or cavities of the mold as required to give a complete part or parts that are free of flash and porosity.

Flash: Any excess material that is formed with and attached to the component along a seam or mold parting line.

Flow (Fill) Rate: the volume of material passing a fixed point per unit time.

Gate: The channel through which the molten resin flows from the runner into the cavity.

Hopper Loader: Auxiliary equipment for automatically loading resin pellets into machine hopper.

Injection Molding Pressure: The pressure applied to the cross-sectional area of the molding cylinder.

Injection Molding: The method of forming objects from granular or powdered plastics, most often of the thermoplastic type, in which the materials is fed from a hopper to a heated chamber in which it is softened, after which a ram or screw forces the material into a mold. Pressure is maintained until the mass has hardened sufficiently for removal from the mold.

Injection Pressure: The pressure on the face of the injection screw or ram when injecting material into the mold, usually expressed in PSI.

Insert Molding: Insert molding is the process of molding plastic around preformed metal inserts. This process is compatible with both thermoplastic and thermoset materials.

Insert: a removable part of the mold imparting increased resistance to wear, heat transferability, or changeable part shape to that area of the mold.

Machine Shot Capacity: Refers to the maximum volume of thermoplastic resin which can be displaced or injected by the injection ram in a single stroke.

Material Safety Data Sheets: Documentation regarding the toxicity or hazards associated with contact with some substances. The manufacturer of the plastic prepares these data sheets.

Mechanical Property: Properties of plastics which are classified as mechanical include abrasion resistance, creep, ductility, friction resistance, elasticity hardness, impact resistance, stiffness and strength.

Melt Flow Rate: A measure of the molten viscosity of a polymer determined by the weight of polymer extruded through an orifice under specified conditions of pressure and temperature. Particular conditions are dependent upon the type of polymer being tested.

Melt Flow: Rate of extrusion of molten resin through a die of specified length and diameter. The conditions of the test (e.g. temperature and load) should be given. Frequently, however, the manufacturer's data lists only the value, not the condition as well.

Melt Index: The amount of a thermoplastic resin, measured in grams, which can be forced through a specified orifice within ten minutes when subjected to a specified force. (ASTM D-1238)

Mold (n): A hollow form or matrix into which a plastic material is placed and which imparts to the material its final shape as a finished article.

Mold (v): To impart shape to a plastic mass by means of a confining cavity or matrix.

Mold Temperature: the temperature at which the mold is maintained. Often the most important benefit of raising mold temperature is that it allows a slower injection rate without the plastic getting too cold.

Multi-Cavity Mold: A mold having two or more impressions for forming finished items in one machine cycle.

Nozzle: hollow metal hose screwed into the extrusion end of the heating cylinder of an injection machine designed to form a seal under pressure between the cylinder and the mold.

Overpack: melt will fill the easiest flow path first and will continue to pack this area while material reaches the other areas. This is a cause of warping created by unbalanced flow.

Packing: The filling of the mold cavity or cavities as full as possible without causing undue stress on the molds or causing flash to appear on the finished parts. Over- or under-packing results in less than optimum fill.

Parting line: mark on the part indicating where the two halves of the mold met in closing.

Pellets: Tablets or granules of uniform size, consisting of resins or mixtures of resins with compounding additives which have been prepared for molding operations by extrusion and chopping into short segments.

Platens: The mounting plates of a press on which the mold halves are attached.

Prototype Tool: A preliminary mold built upon which the final mold will be based.

Purging: In extrusion or injection molding, the cleaning of one color or type of material from the machine by forcing it out with the new color or material to be used in subsequent production, or with another compatible purging material.

Runner: In an injection mold, the feed channel, usually of circular cross section, which connects the sprue with the cavity gate. The term is also used for the plastic piece formed in this channel.

Shot Capacity: Generally based on polystyrene, this is the maximum weight of plastic that can be displaced or injected by a single injection stroke. Generally expressed as ounces of polystyrene.

Shrinkage Allowance: The dimensional allowance which must be made in molds to compensate for shrinkage of the plastic compound on cooling.

Sink Mark: an indentation on the surface of the part as a result of significant local change in wall section. The mark will occur in the thicker area.

Sprue: The feed opening provided in injection molding between the nozzle and cavity or runner system.

Thermoset: A polymer that doesn't melt when heated. Thermoset polymers "set" into a given shape when first made and afterwards do not flow or melt, but rather decompose upon heating. They are often highly cross-linked polymers, with properties similar to those of network covalent solids, i.e., hard and strong.

Tie-Bar Spacing: The space between the horizontal tie-bars on an injection molding machine. Basically, this measurement limits the size of molds that can be placed between the tie-bars and into the molding machine.

Tonnage: The measure by which injection molding machines are typically categorized, representing the clamping force of the injection molding machine.

Tool: In injection molding, the term sometimes used to describe the mold.

Undercut: A protuberance or indentation that impedes withdrawal from a two-piece rigid mold.

Vent: A shallow channel or opening cut in the cavity to allow air or gases to escape as the melt fills the cavity.

Virgin Material: Any plastic compound or resin that has not been subjected to use or processing other than that required for its original manufacture.

Warpage: Distortion caused by nonuniform internal stresses.

Weld Line: Where melted material flows together during molding to form a visible line or lines on a finished part that may cause weakening or breaking of the component.

Safety Precautions

APSX-PIM is a small and low pressure machine. However, the following safety precautions should be taken before and during the machines use.

Thermal effects:

Skin contact with molten plastic can inflict severe burns. This could happen when the machine under pressure ejects molten plastic through the nozzle.

To minimize the chance of an accident, potential hazards must be anticipated and should be eliminated or guarded properly. Purging should be performed carefully with the guard gates closed. The trapped gas in the cylinder may cause splattering at the beginning of the purging process.

Molten plastic material can appear cool on the surface, but remain very hot on the inside. Wear personal protective equipment when handling hot plastic material.

ALWAYS ASSUME GAS AT HIGH PRESSURE COULD BE TRAPPED BEHIND THE NOZZLE AND THAT IT COULD BE RELEASED UNEXPECTEDLY.

A face shield or safety goggles, heat resistant protective gloves, safety shoes, non-melting fiber pants and long sleeve shirts should be worn at all times.

In the event that molten polymer does contact the skin, cool the affected area immediately with cold water or an ice pack and get medical attention for a thermal burn. Do not attempt to peel the polymer from the skin.

The machine has multiple parts that have high temperature levels that the user should never touch with bare hands. Those parts are electric motors, cylinder barrel, mold structure and hopper assembly.

Off-Gases Ventilation:

During the molding some amount of gas is released. As a general principle, local exhaust ventilation is recommended during the process of all plastic heating. Injection molding normally releases substantially less volatile material so it requires less ventilation. But during purging, volatile releases are similar to that in extrusion. Extra care in avoiding the inhalation of fumes is recommended. Local exhaust ventilation should be used to convey such fumes outside the workplace.

Slipping Hazards:

Pellets of plastics are a slipping hazard if spilled on the floor. They are cylindrical in shape and have a low coefficient of friction. Any spills should be swept up or cleaned immediately. There should be a vacuum cleaner available to collect spilled pellets from the ground.

Physical Hazards:

The machine has multiple moving mechanical parts under load. Placing hands in between those moving parts such as springs, metal blocks, chains and cylinders can be a cause to a serious injury. Never reach into the machine when it is going through its injection cycle.

The machine is too heavy for one person to move or lift. Never try to move or lift the machine without proper equipment. Do not exceed the rated capacity of the lifting equipment.

Electrical Hazards:

The machine uses 115VAC power. Touching it to uncovered electrical control panel parts can put you at risk of fatal injury.

NEVER UNPLUG THE MACHINE WHEN THE SPRING IS PRESSED OR WHEN THE RED LIGHT IS ON UNDER ELECTRONICS COVER!

The quality, rating, and insulation of electrical power wires and cables have been selected specifically for the requirements of this machine. Damaged cables must be replaced immediately with the same or higher quality cables than those specified for the machine.

Other Safeguards:

The machine should only be used for its intended purpose by an authorized and trained individual as described in the manual.

Never leave the machine unattended without placing a warning sign around it for others not authorized to use the device.

Make sure the machine is securely placed to a safe table or bench before operating.

During maintenance always shut the power off.

Never try to inject the plastic until it has reached proper operating temperature.

Never leave the heaters on for any extended length of time when the machine is not being operated.

The maximum temperature set is set below the ignition point of the material being processed.

Only original APSX parts should be used for replacement.

Regularly inspect all assemblies and screws connecting different sections and parts.

Safety Alerts:

The **DANGER** safety alert indicates an imminently hazardous situation that if not avoided, could result in death or serious injury.

The **WARNING** safety alert indicates a potentially hazardous situation that if not avoided, could result in death or serious injury.

The **CAUTION** safety alert indicates a potentially hazardous situation that, if not avoided, could result in property damage.

APSX-PIM Injection Molding Machine

APSX-PIM is a fully automatic electric desktop injection molding machine. It runs with 115VAC power with no water or hydraulic connection required. It can generate 5 tons of clamp force and can inject 30 cu-cm of plastic at a time up to 300 C degrees. Standard mold size is 6" (H) by 4.8" (W).

APSX-PIM consists of multiple small sections. The machine is controlled by electric motors and precise sensors. The user has touch screen PC attached to the machine for setup and operational controls.

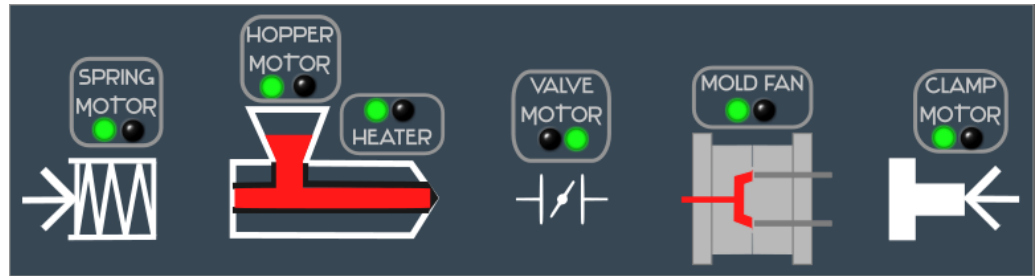

The main sections are listed below:

- Plasticizing section
- Pre-plasticizing section
- Injection section
- Injection valve section
- Clamping section
- User interface section

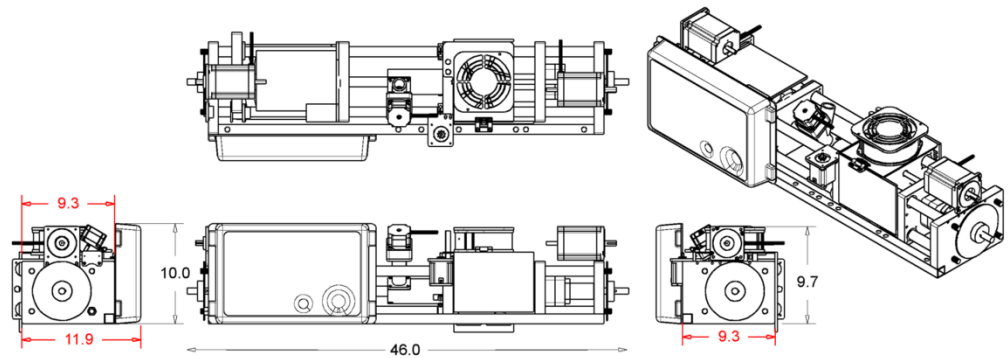

Plasticizing Section

The plasticizing section melts plastic pellets and contains them at a set temperature for the injection process. It has an electronically controlled/heated cylinder barrel, thermocouple, heater and insulation parts. It touches to the injection, valve and pre-plasticizing sections.

Pre-Plasticizing Section

The pre-plasticizing section allows the transfer of plastic pellets and moves them into the cylinder barrel in the plasticizing assembly. It includes the hopper motor, hopper and hopper feeder. It also prevents the backward flow of pellets to the hopper feeder when the injection plunger injects the pellets into the mold cavity. The hopper feeder with a screw in it can control the amount of metered plastic material to be transferred from the hopper to the cylinder barrel. Hopper which is 5.44kg (12lbs) capacity can be fed either manually or with an automatic feeder.

Injection Section

The injection section is secured to a movable structure that can move the plunger horizontally. Injection assembly applies linear injection pressure onto the melted plastic within the plasticizing assembly. It uses the spring, injection motor and plunger. The plunger is connected to the spring by a precision ball screw. The injection motor compresses the spring to push the plunger into the cylinder barrel. All actions of the plunger and the spring compression are precisely controlled by linear motion control sensors.

Injection Valve Section

The injection valve section controls the flow of the pressurized melted plastic into the plastic mold cavity. It includes the valve pin and the valve motor. The injection valve section is connected to the tip of plasticizing assembly with screws. The pressurized hot plastic travels the cylinder barrel when the plunger pushes it within the cylinder bore along a flow path into the mold cavity. The flow is adjustable for various plastics by electronically controlling the degree of opening angle of the valve pin positioned in a metal block. It can be controlled by the valve motor interconnected to the pin through the sprocket mechanism.

Clamping Section

The clamping section holds the opposite injection pressure on the mold by applying force against the injection force generated by the injection assembly. It has the clamping motor and the cooling fan. The clamp force is adjusted electronically by using a pressure sensor. There is also an ejector mechanism attached to the clamping section that allows automatic ejection of the part from the mold.

User Interface Section

The user interface section provides full control to the user. Its two parts are the electronics board panel and the touch screen tablet PC. It allows the user to set the operational and material related parameters on screen within the pre-set ranges. The 115VAC power input from a regular wall outlet is also included in this section.

Moving the APSX-PIM to Another Location

Please be aware of the following precautions when moving the APSX-PIM to another location or carrying it out from the shipping crate.

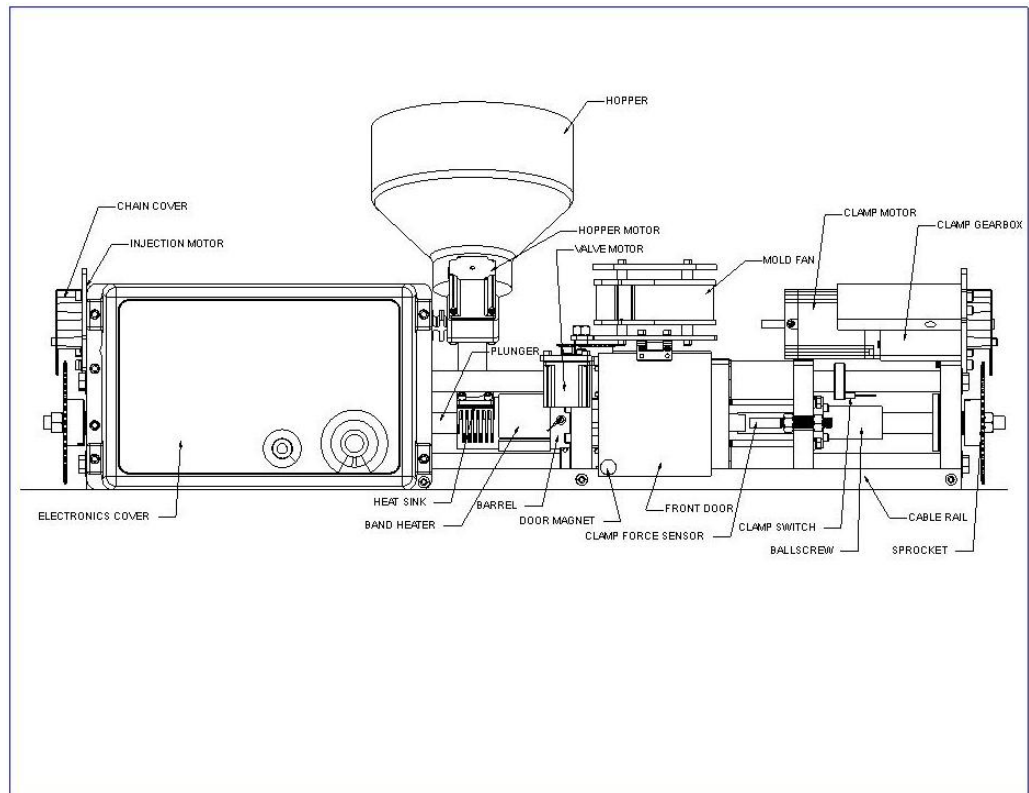

1 – Always use the chain hook holes located on the clamp motor and injection motor mounts. They are designed specifically for lifting. You can use a small size hydraulic lift or a similar tool.

2 – Never use the cable rail as your carrying point since it is not designed to hold much force. Also, it is very sensitive to bending and pushing movements because it carries multiple sensors that control the machine.

3 – Never use the tablet holder as your carrying point. It is only for holding the tablet PC.

APSX-PIM Injection Molding Process

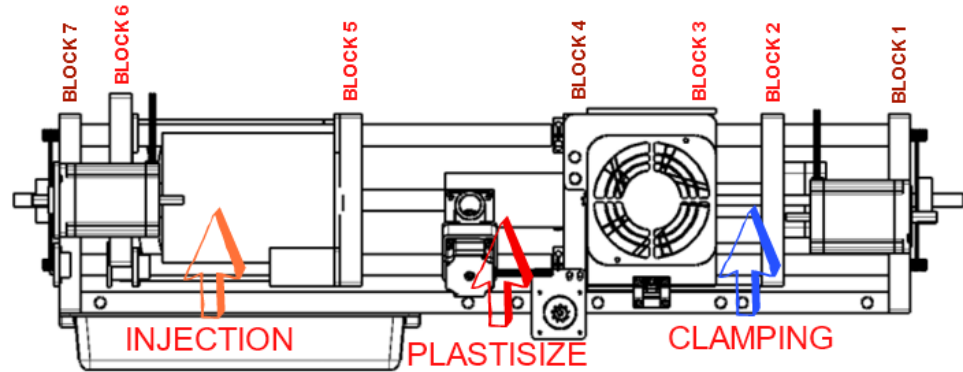

APSX-PIM TOP VIEW

Preparing the Machine

The user must check if the machine hopper and hopper feeder pipes are cleaned and there are no obstructions from the previous injection session. Otherwise the hopper system may not be able to feed the barrel with enough plastic pellets.

Powering the Machine

The user powers the machine from a regular 115VAC wall outlet then connects the USB cable to the tablet. Using a voltmeter display on the connection can help monitoring voltage fluctuations to ensure your machine is operating within its specified limits. When the machine has multiple motors and heaters are turned on, the VAC value should not drop below 114VAC. Otherwise the machine would not have 100% power and processes may take longer or may never be completed.

System ON

The user pushes the SYSTEM button to turn on the main components such as motors and sensors.

Installing the Mold

In this step, the user places and secures the injection mold kit and adjusts the ejector pins on the mold for a perfect ejection process if the automatic multi-injection mode is intended for use.

Press the “Engage Clamp” button on the tablet until the movable platen stops. Disassemble and put aside the mold fan assembly by unscrewing the two nuts located on the fixed platen at Block 4. Then start placing four mold clamp claws by using a wrench.

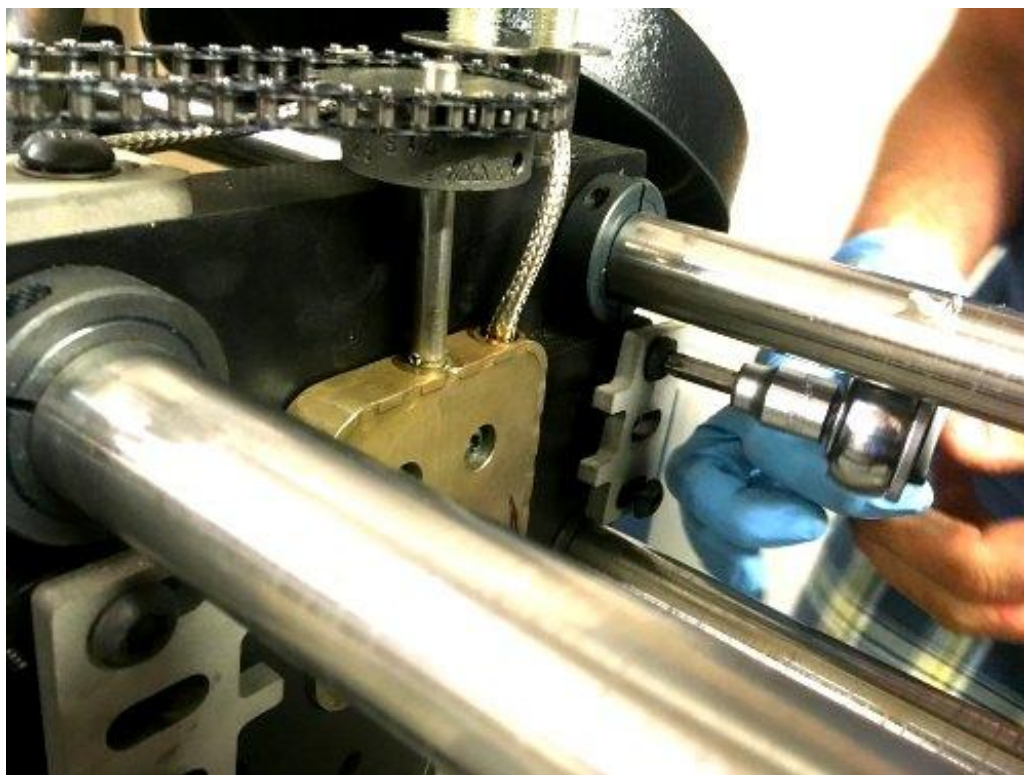

Move the ejector rod back out of the moving mold platen at Block 3 to create enough space for the mold piece to slide down as shown below.

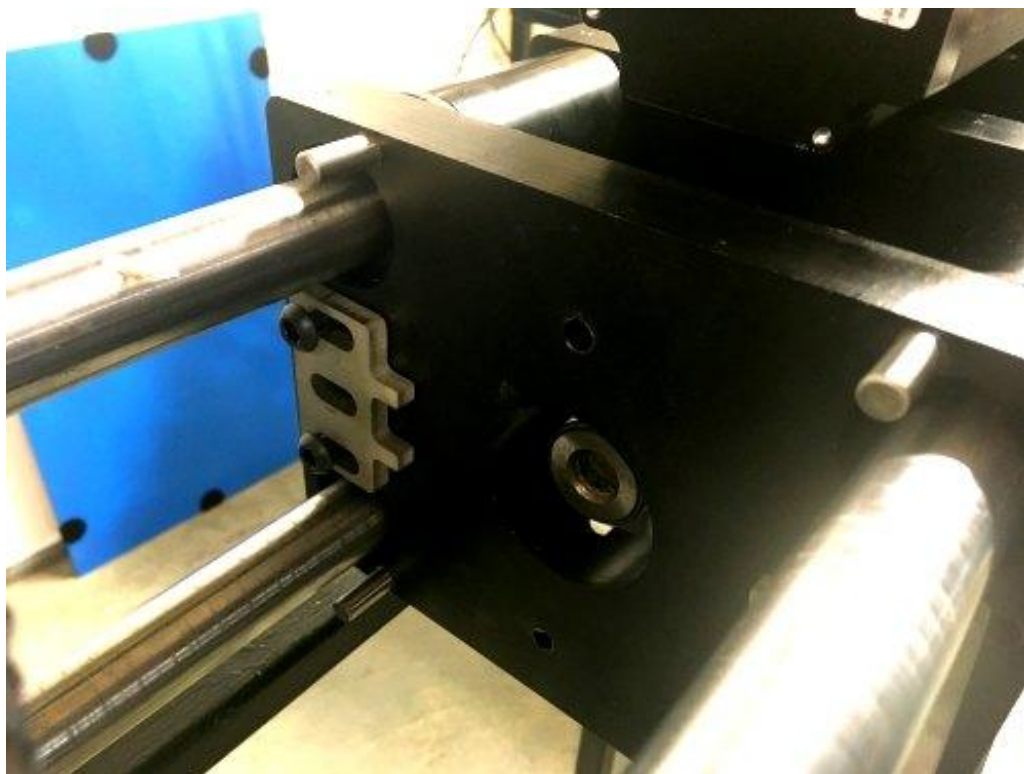

APSX-PIM DESKTOP INJECTION MACHINE

While holding the mold by hand as shown below, lower it slowly until the top edges of Block 3 and the mold are aligned properly.

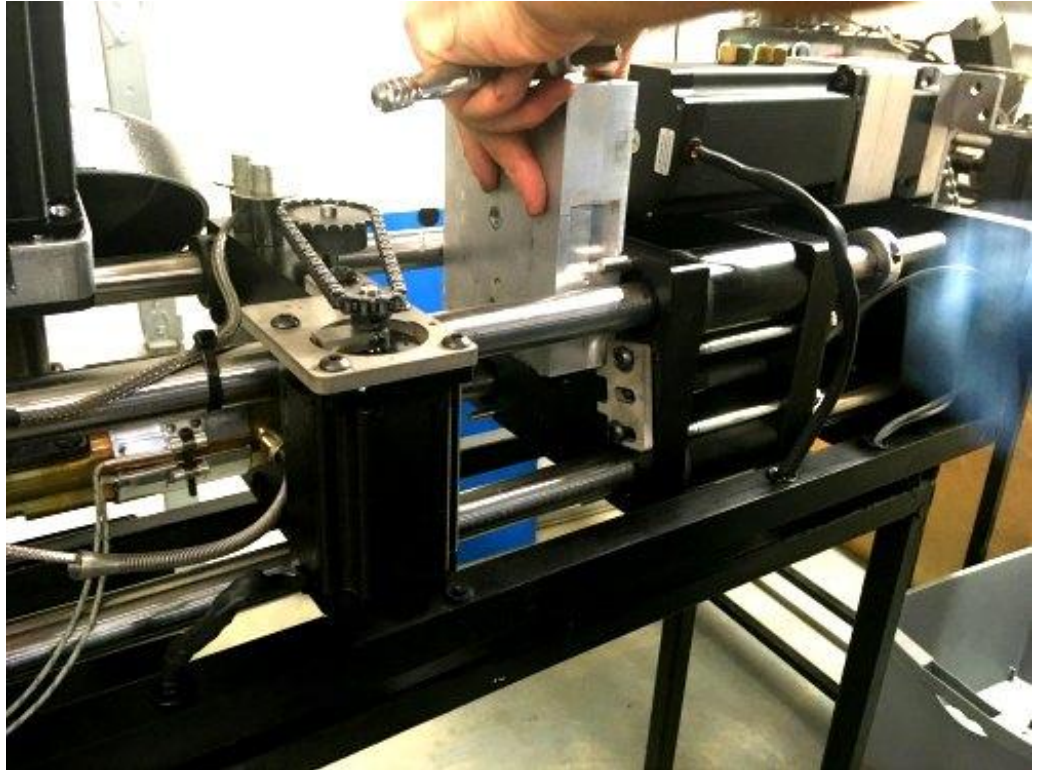

Tighten the mold clamps on the moving platen with bolts and release your hands.

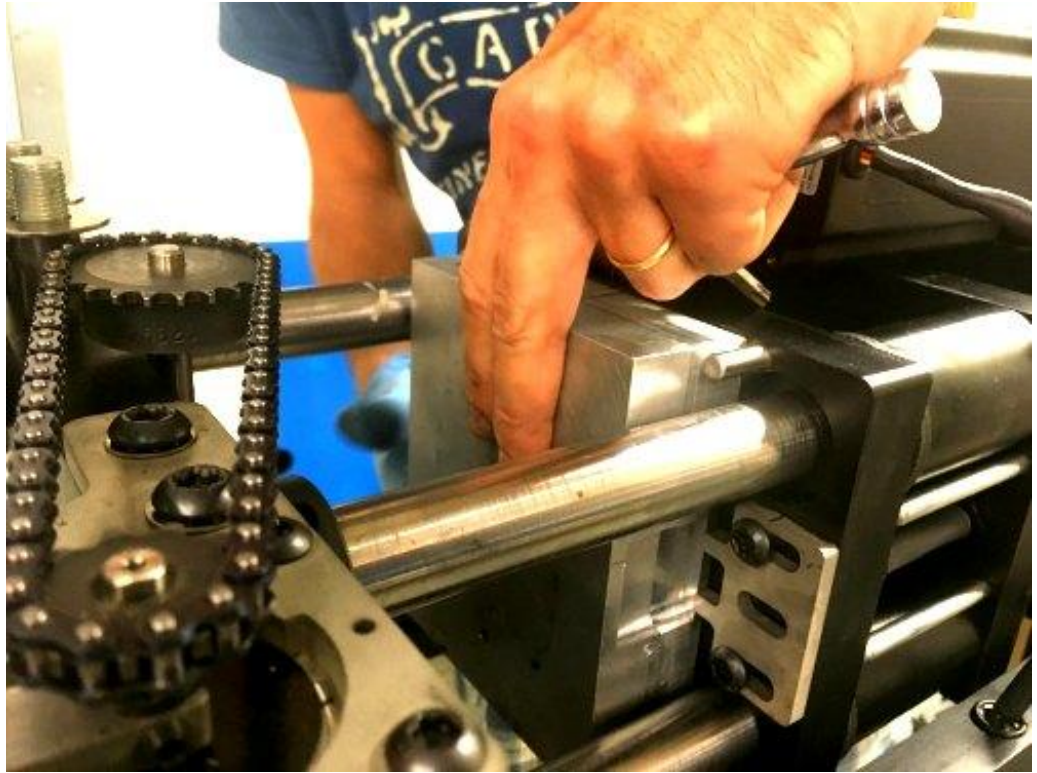

Clamp the mold by moving the clamp side of the machine manually on touch screen by using “Engage Clamp S” button until the mold is securely clamped between fixed (Block 4) and moving platens (Block 3). Watch that the clamps are not caught between the mold and the block 4. Then tighten the mold clamp screws on the fixed platen side of the mold.

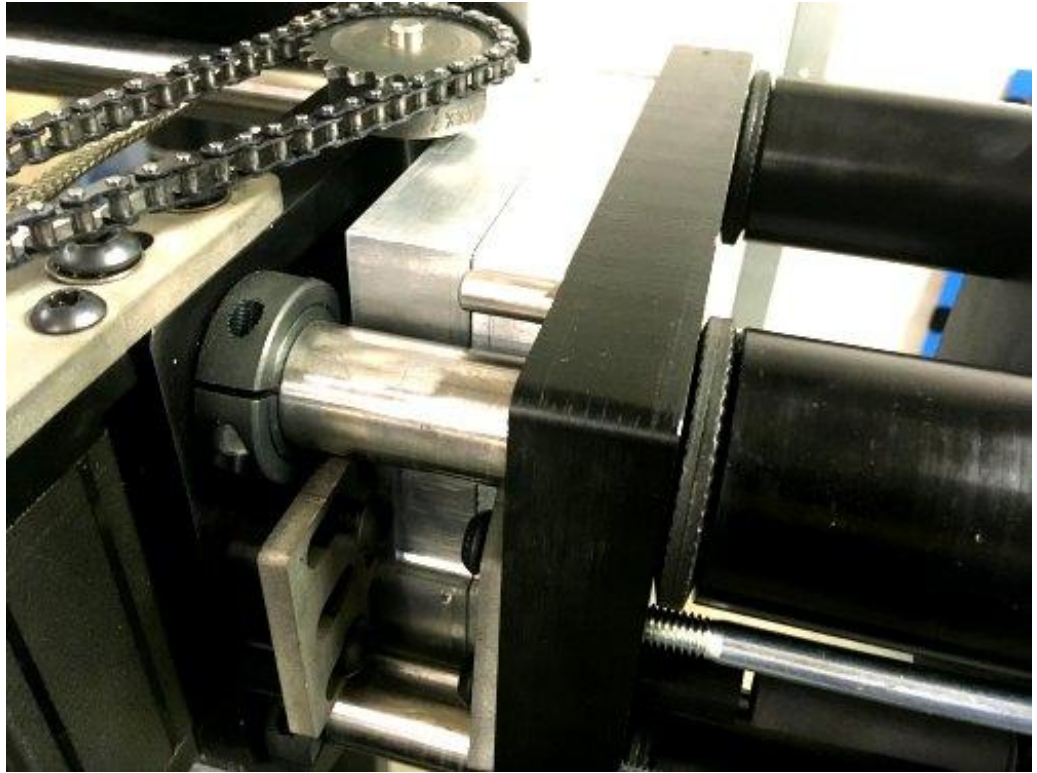

Open the mold manually by pushing on the Home Clamp button on touch screen manual controls to allow you enough space to complete the tightening the mold clamps.

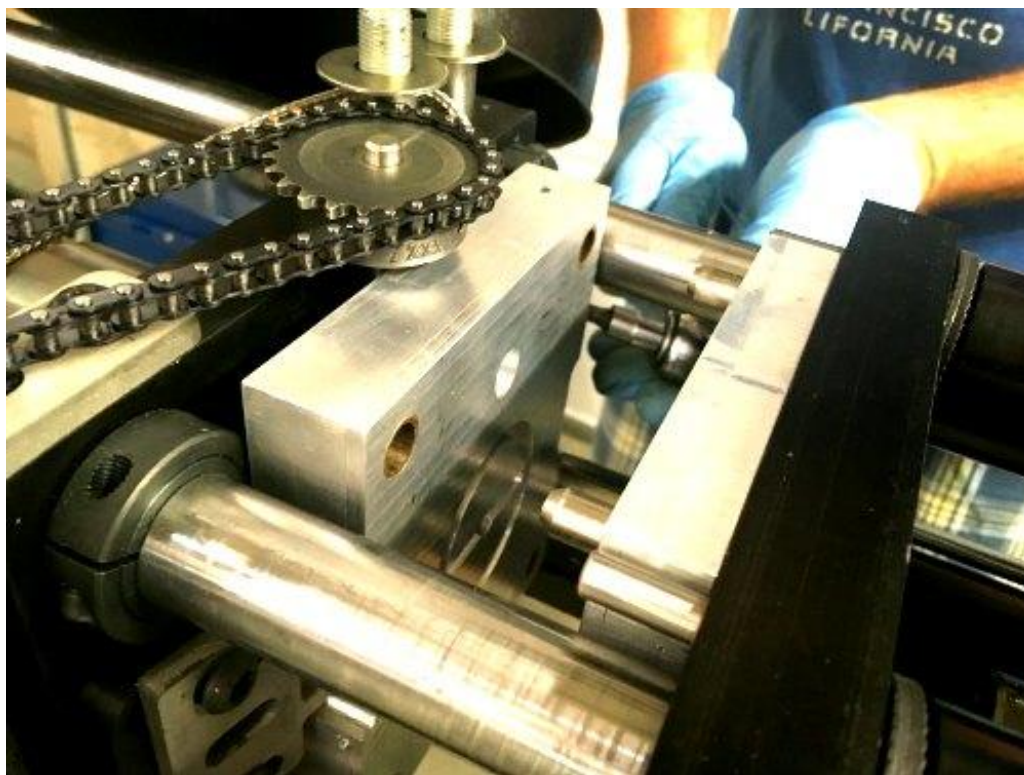

Connect the mold temperature sensor by using the screw on the mold.

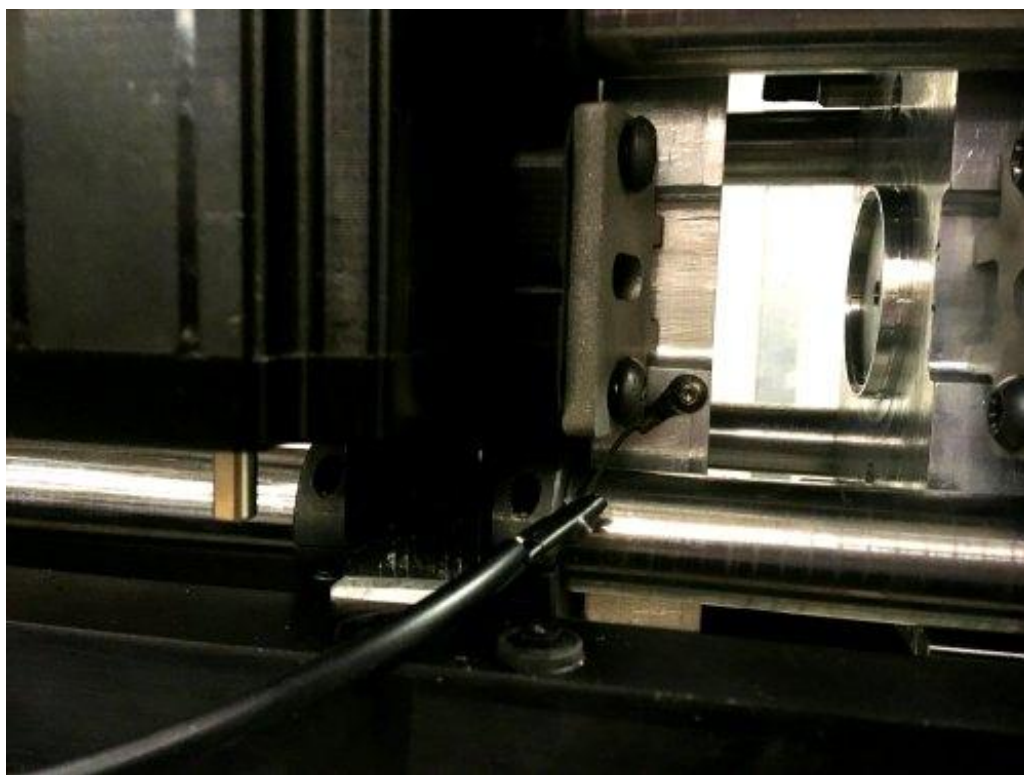

APSX-PIM DESKTOP INJECTION MACHINE

Place the mold fan assembly back to its place by tightening the two nuts located on the fixed platen (Block 4).



Securely close the front and back doors on the mold fan assembly as shown below.



PLEASE NOTE: Remember this is a critical step; the clamp switch stops the machine when the clamp side is homed. If it does not work properly or placed too far from the mold, it will not stop where it is supposed to and can damage the machine and the mold. For example, the ejector bearing will hit the mold plate when homing and may damage the mold or the ballscrew if the clamp switch is not properly positioned. Watch for the **CLAMP SWITCH check box** at the bottom of the user screen. It shows “checked” where the machine stops when homing. **WATCH YOUTUBE VIDEO:** Injection Molding Ejection Mechanism - How to Adjust APSX-PIM (<https://youtu.be/SSBCsWZTiBQ>)

Adjust the location of the clamp switch collar located on the steel frame bar between Block 1 and Block 2 by sliding it according to the ejector rod location while referencing the mold geometry. The ejector rod should touch to the ejector plate and complete the ejection process when the block gets into the clamp switch range.

APSX-PIM MAGNETS, SWITCHES AND SENSORS:

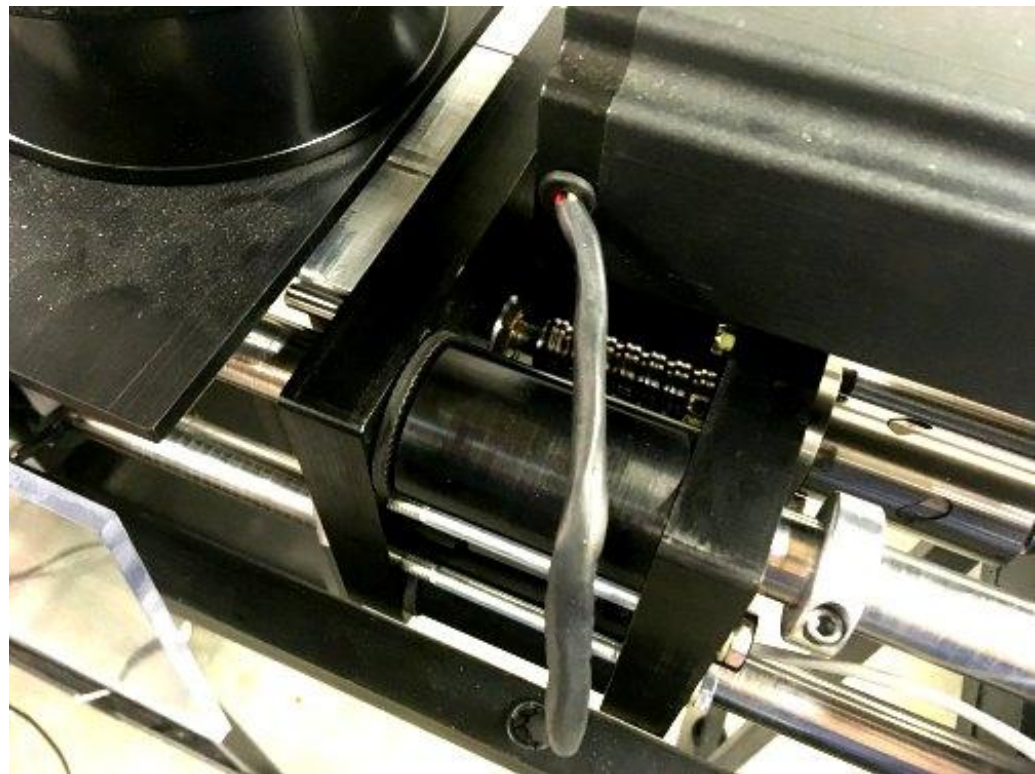
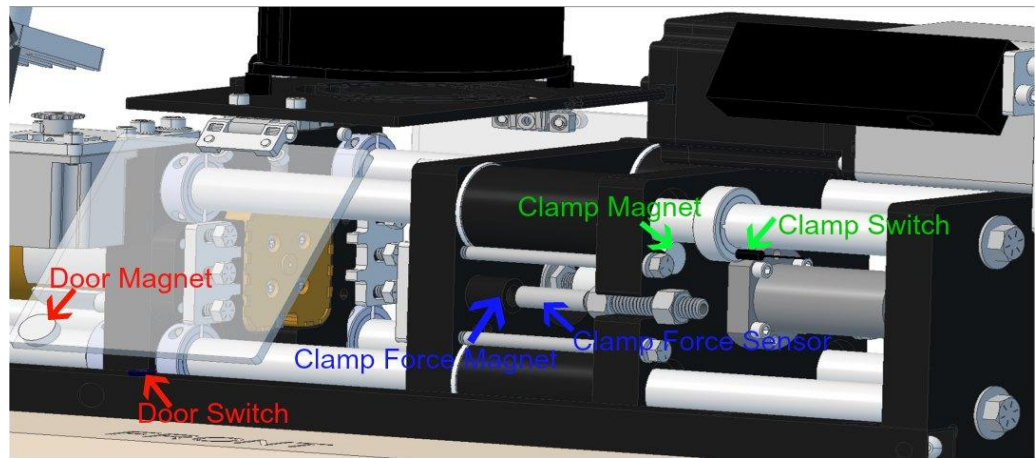

Perform the final test of the ejection system on MANUAL CONTROL mode and fine tune it after each try. Manual controls are for fine tuning the machine for each mold. They are not for performing injection molding “manually”.

APSX-PIM CYCLE:

The machine performs the injection molding functions of plasticizing, clamping, injection and ejection accordingly and completes the job as set by the user. These automatic steps are for one single injection cycle.

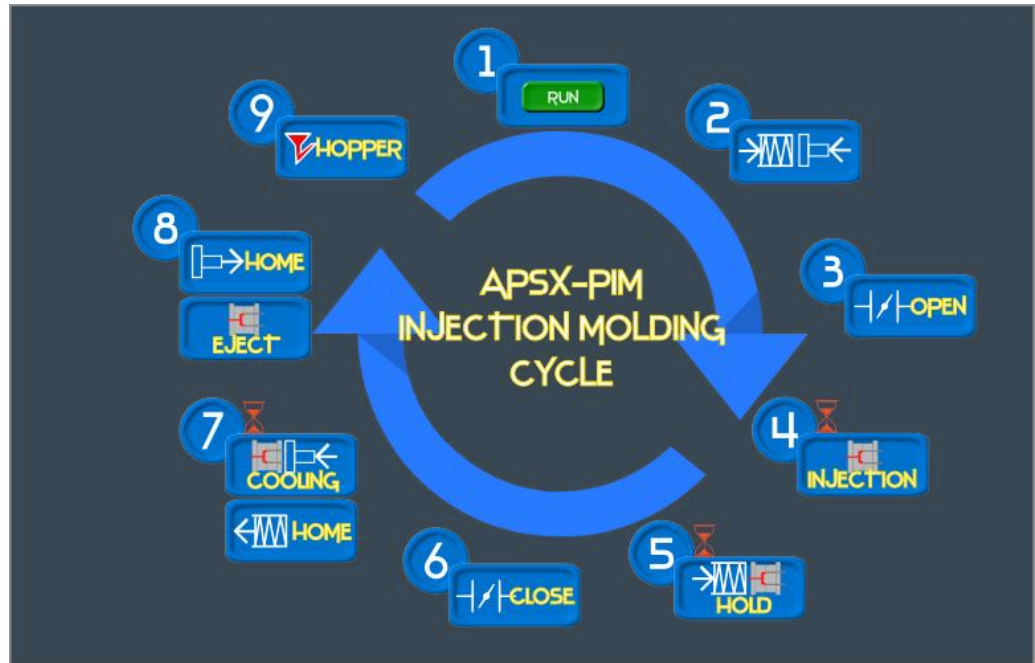

Settings

The user interface on the tablet PC is connected to the machine via USB cable is ready for the set up process. The user sets the desired injection temperature, shot size, timings and other operational parameters on tablet PC screen. The user screen shows the actual and target settings for each parameter.

APSX-PIM User Screen

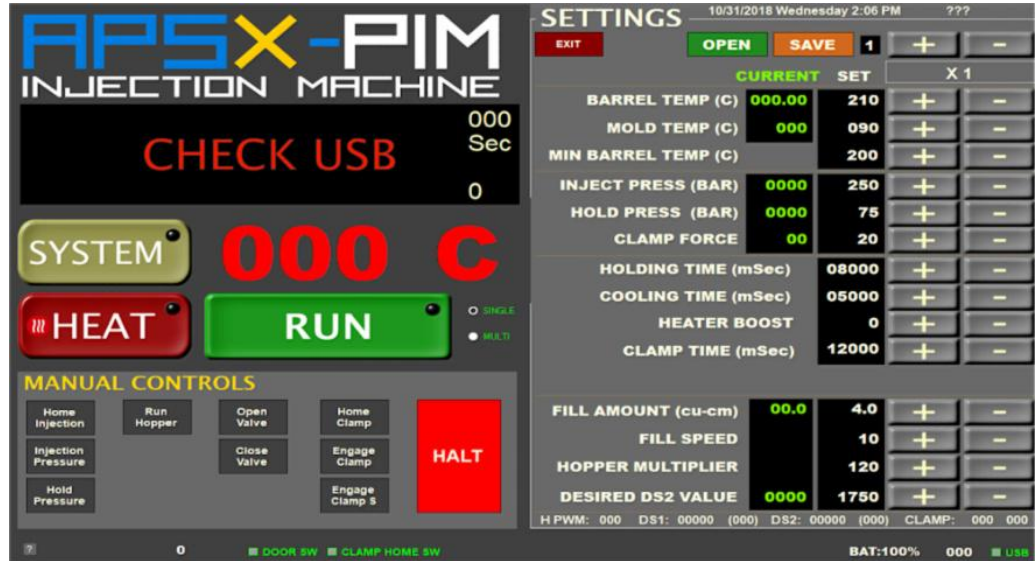

MAIN DASHBOARD



Status Message – Informs the user which step of the injection cycle is in process.

STAND BY: Ready for the operation command.

CLAMPING: Clamp (Block 2 & 3) is approaching the mold area. Be cautious and do not stand too close to the machine.

INJECTING: The nozzle opens and plastic is being injected into the mold cavity between Block 4 & 3.

HOLDING: The pressure drops to the holding pressure level to secure a 100% fill rate.

COOLING: The machine is waiting for the injected plastic to cool enough to be ejected.

HOMING: Clamp (Block 2 &3) and injection sides (Block 5&6) travel to their home locations for the next injection cycle.

SYSTEM Button – The button to turn ON or OFF the APSX-PIM system components such as motors and sensors.

HEAT Button – The button to turn ON or OFF the heat on the barrel.

PLEASE DO NOT LEAVE THE MACHINE IDLE ABOVE MELTING TEMPERATURE MORE THAN 30 MINUTES. THIS MAY CAUSE DETERIORATION OF THE PLASTIC PELLETS. THE HOPPER ENTRY PIPE CAN ALSO CLOGG AND MAY NEED TO BE CLEANED.

Temperature Display – The current temperature of plastic in the barrel

RUN Button – The button to start or stop the APSX-PIM injection cycle

Cycle Timer – The timer that shows each cycle time in seconds

Part Counter – The cycle count for each session. Press once to reset.

Single/Multi Modes – Machine stops once it completes one cycle at single mode. Hit Run to start another cycle. Machine continues to run without stopping at multi mode. Never use that mode if you do not have ejection mechanism on your mold.

SETTINGS



This section is to set the temperature, pressure, force, time and part characteristics. At the same time, the actual real-time readings are shown where possible.

The + and - buttons can be used to change the settings. The user can OPEN or SAVE a “settings profile”. Settings “1” comes with the machine and is used for the Test Mold installed on the machine with provided PP pellets. To change the settings number from 1, the plus button can be used. Then you can save your own profile as “2”.

The X1 button on top is to change the multiple of the increase or decrease action. When it is on X10, the parameters change with bigger steps rather than one by one increment.

TEMPERATURES

Barrel Temperature – The current and set temperatures of the plastic in the heated barrel.

Mold Temperature – The current and set temperatures of the mold block. Mold can be kept at about 55C-60C minimum at room temperature by using the default fan system. A cooling method would be required if mold has to be at much lower temperatures.

Minimum Temperature – The set minimum temperature required to run the injection machine. If the temperature drops below that threshold, it will wait to reach that temperature before running to protect the machine from getting damaged. It should be set higher than material's melt temp at least.

PRESSURES / FORCES

Injection Pressure – The current and set pressures that are applied to the plastic **in the barrel**. Almost 90% of the part volume is injected at this high pressure. Each plastic material has a unique “suggested” injection pressure as a guideline.

Hold Pressure – The current and set holding pressures that are applied to the plastic **in the mold**. The rest of the part will be injected to complete at this pressure.

Clamp Force – The current and set forces applied to the **closed mold** when it is clamped. Test mold has it at 20. Typically 35-50 range is max. For higher values the machine aborts the cycle if it cannot reach to that value.

TIMES

Holding time – The time set to keep holding pressure.

Cooling Time – The time set to keep plastic in the mold after holding pressure.

Heater Boost – The additional power (W) applied to heaters to keep the set temperature when the temperature drops below the minimum temperature set for multi mode.

Clamp Time – The time set to move the clamp at its fastest speed towards the mold before slowing down for clamping. Please start low to not bang the clamp on the mold.

PART CHARACTERISTICS

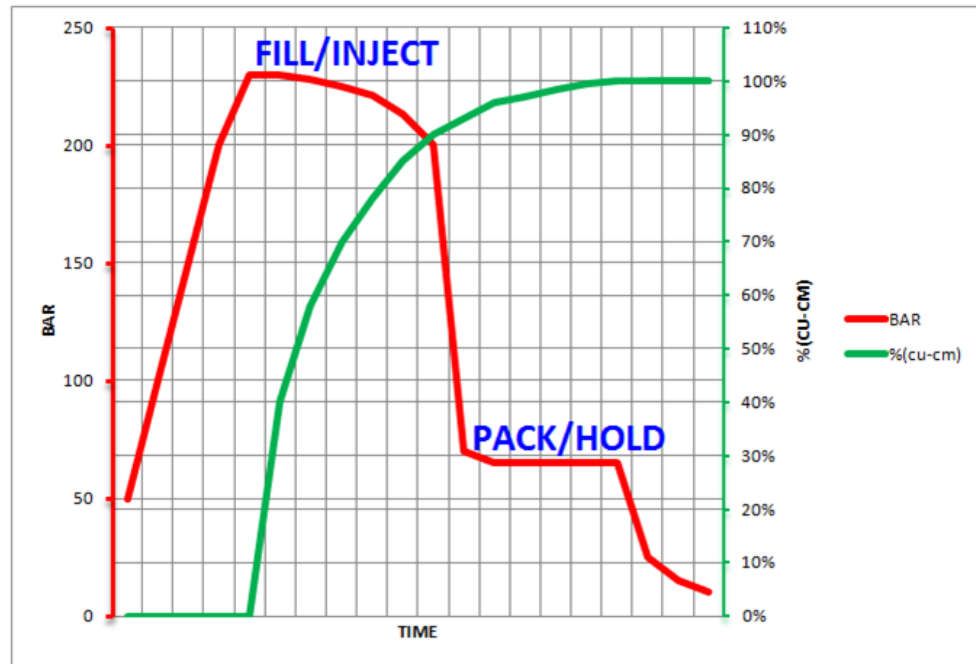

Fill Amount – The switch over volume that the machine uses to decrease the pressure from high pressure (injection pressure) to low pressure (holding pressure). APSX recommends this number to be set at 90% of the total part volume. *For example, if your total part volume including the sprue is 10cu-cm then set fill amount to 9cu-cm.*

The green number on the CURRENT column shows “real-time” fill in cu-cm. It will be higher than set volume (90%) when the injection is complete.

Fill Speed – The injection speed (rate) of the fill action set in seconds. Each mold design may require faster or slower injection depending on the mold design and plastic being used.

Hopper Multiplier –Set this amount depending on the injection cycle results achieved. If the part being injected is missing plastic, the user can increase the hopper multiplier. If the discharge tube discharges too much plastic per cycle, the user can decrease the hopper multiplier.

Desired DS2 Value – Please do not change this value unless you see short parts or too much discharge from the discharge tube on the barrel. The default value should work almost all of the molds to have optimum amount of pellets added to the barrel at multi mode so that the cycles keep going uninterrupted.

MANUAL CONTROLS



Manual controls help for fine tuning the machine for each mold but are **NOT to perform the injection cycle “manually”**. If the user wants to run the injection cycle manually instead of on automatic mode, this section has control buttons that can be used very carefully. In general, the **standard APSX-PIM injection cycle should be used**. These control buttons can also be used for testing movements of the machine components. To stop the action, please press the HALT button.

Home Injection –Sends the injection spring back to its home location

Injection Pressure – Triggers the spring movement to generate the injection pressure up to the set level – do not use until barrel temp reaches to set temp.

NEVER UNPLUG THE MACHINE WHEN THE SPRING IS PRESSED OR WHEN THE RED LIGHT IS ON UNDER ELECTRONICS COVER!

Hold Pressure – Moves the spring to the position which keeps its pressure at the set holding pressure – do not use until barrel temp reaches to set temp.

Run Hopper – Moves plastic pellets to the barrel - HALT to stop– do not use until barrel temp reaches to set temp.

Open Valve – Opens the injection nozzle valve 100% to let the under-pressure hot plastic flow into the mold cavity– do not use until barrel temp reaches to set temp.

Close Valve – Closes the valve keeping under-pressure hot plastic in the barrel

Home Clamp – Moves the clamp mechanism back to its home base, the clamp switch collar location is set by the user and determines the clamp home location

Engage Clamp – Triggers the clamp mechanism movement in fast speed mode towards the mold area - HALT to stop

Engage Clamp S – Moves the clamp mechanism in slow speed mode towards the mold area – HALT to stop

HALT – When performing manual functions, halt stops any motor in its current position. Press halt in RUN mode to stop the cycle in progress and home all motors.

E-STOP – Turns off all motors, shuts the SYSTEM off and disables HEAT.

STATUS INDICATORS

The check boxes at the bottom of the screen indicate when the switches are on or off. USB status is also shown as “CONNECTED”. Tablet PC battery level is also shown.

Filling the Hopper

User places the plastic pellets into the hopper manually or via auto loader (not included).

Start the Heat



After pressing HEAT on the tablet, the cylinder barrel is heated to the set temperature. In general, it needs about 15 minutes to heat to the set temperature. **NOTE:** the machine will not RUN before reaching its set minimum temperature.

PLEASE DO NOT LEAVE THE MACHINE IDLE ABOVE MELTING TEMPERATURE MORE THAN 30 MINUTES. THIS MAY CAUSE DETERIORATION OF THE PLASTIC PELLETS. HOPPER ENTRY PIPE CAN ALSO BE CLOGG AND MAY NEED TO BE CLEANED.

Manually Controlling

Manual controls can be used for testing each component for functionality, new mold installation and purging. It is important to set lower pressure settings to safely operate manual controls.

Purging

Warning: USE PERSONAL PROTECTIVE EQUIPMENT BEFORE PURGING.

SAFETY: PRESSURIZED HEATED PLASIC CAN CAUSE SEVERE BURNS. NOZZLE VALVE SHOULD BE OPEN AT ALL TIMES DURING PURGING TO PREVENT SPLATTERING.

If all motor movements are verified ok in manual-operation state, you can perform the purging process. Ideally, use a purging material, natural LDPE plastic pellets or an equivalent product. Repeat the purging process 3-5 times with manual controls until all the old material is removed from barrel.

- Load the hopper with purging material and run the hopper until the barrel is full

- Set the HEAT on and wait until minimum 200 C or until you've reached the specific melting point of your plastic.
- Open the mold HOME CLAMP and keep in open position
- Set the holding pressure at a low pressure i.e., 25
- Open the valve
- Take your safety measures with goggles and have the mold gate closed
- Use HOLD PRESSURE button to start the purging process
- Once plunger has pressed all the way into barrel press HOME INJECTION
- Repeat this process multiple times until the discharged material is visually the same as the purging material

Start RUN



Press the RUN button on tablet, the machine starts the fully automatic single injection cycle.

NEVER UNPLUG THE MACHINE WHEN THE SPRING IS PRESSED OR WHEN THE RED LIGHT IS ON UNDER ELECTRONICS COVER!

Stopping the Machine

The injection spring and clamp motors must be homed before shutting down the machine. Check if the mold has any parts left on it or not. First HEAT then the SYSTEM must be tuned off. Please wait until plastic temperature is down to about room temperature to turn the ventilation system off. Now it is safe to unplug the machine.

Cleaning the Machine

The user must empty the hopper. Plastic pellets can be vacuumed from the hopper feeder pipe for the next injection session. A flat edge tool can be used to clean excess hardened plastic that may have stuck to the machine or molds.

Troubleshooting Guide

Please follow the troubleshooting matrix below in the numerical order of recommended actions.

Suggested Actions (Try in order recommended)	Problem Areas																
	Increase Injection Pressure	Decrease injection pressure	Increase fill speed	Decrease fill speed	Increase barrel temperature	Decrease barrel temperature	Increase mold temperature	Decrease mold temperature	Increase nozzle/barrel temperature	Decrease nozzle/barrel temperature	Increase size of gate	Enlarge vents	Decrease cycle time	Increase cycle time	Increase clamp pressure	Repair mold	Change gate location
Drooling						2				1		3					
Short Shots	1		2		3		4				6	5					
Sinks	1			2	4	5		3			6						
Voids in Part	1			2	3	4					5	6					
Flash		2		3				4							1	5	
Burn Spots on Part				1		2					4	3					5
Poor Weld Lines	1		2		3		4				5						6
Parts Stick in Mold		1		2										3			
Warpage	2		3	4				5						1			6
Sprue Sticking									2				1				

DO NOT TIGHTEN THE FOUR BOLTS ON BLOCK 2. THEY ARE TIGHTENED TO A SPECIFIC TORQUE SETTING KEEPIN THE CLAMP FORCE MEASUREMENTS ACCURATE.

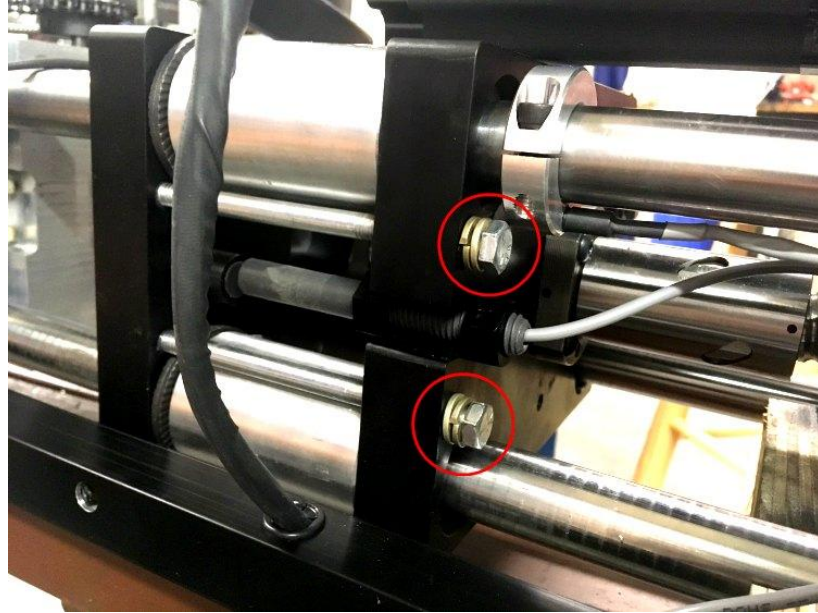

NEVER UNPLUG THE MACHINE WHEN THE SPRING IS PRESSED OR WHEN THERE IS HOT PRESSURIZED PLASTIC IN THE BARREL.

PLEASE DO NOT LEAVE THE MACHINE IDLE ABOVE MELTING TEMPERATURE MORE THAN 30 MINUTES. THAT MAY CAUSE DETERIORATION ON THE PLASTIC PELLETS. THE HOPPER ENTRY PIPE CAN ALSO JAM AND MAY NEED TO BE CLEANED.

ALWAYS ASSUME THAT GAS AT HIGH PRESSURE COULD BE TRAPPED BEHIND THE NOZZLE AND THAT IT COULD BE RELEASED UNEXPECTEDLY. PLEASE USE PERSONAL PROTECTIVE EQUIPMENT AT ALL TIMES WHEN RUNNING.

WE DO NOT SUGGEST USING THE TABLET PC FOR OTHER APPLICATIONS OTHER THEN APSX-PIM SOFTWARE. IDEALLY, IT SHOULD BE DEDICATED ONLY FOR APSX-PIM USE. NOT FOLLOWING THIS SUGGESTION VOIDS THE WARRANTY.

Machine Specs

	SAE	Metric
Piston Dia [in / cm]	1	2.54
Injection Volume [cu-in / cu-cm]	1.83	30
Injection Pressure [PSI / BAR]	5000	345
Clamping Force [lbs / tons]	11023	5
Opening Stroke w/ & w/o Ejector Plate [in / cm]	5.5-7.0	13.97-17.78
Max Processing temp [F / C]	572	300
Weight [lbs / kgs]	250	113
Standard Mold Size [in / cm]	4.8" (W) X 6.0" (H)	12.19cm (W) X 15.24cm (H)
Machine Dimensions [in / cm]	43" (L) X 10" (W) X 15" (H)	109cm (L) X 25.4cm (W) X 38cm (H)
Shipping Crate Dimensions [in / cm]	48" (L) X 16" (W) X 19" (H)	122cm (L) X 40.6cm (W) X 48.3cm (H)
Steel Bar Frame Diameter [in / cm]	1	2.54
Tie Bar Top Clearance [in / cm]	5	12.7
Min Power Supply [V]		115
Heating Power [W]		1250
Plastic Materials for Injection	Polycarbonate (PC), Acetal (Delrin), ABS, PC/ABS, Nylon (PA6), Polypropylene (PP), Polystyrene (PS), Polyethylene (PE), Thermoplastic Polyolefin (TPO)	
Warranty	1 year	

Anodized Hard Aluminum Blocks: 6" X 8" X 1"

User Control: 10" Touch Screen Tablet PC

KEY FEATURES OF APSX-PIM

- Compact design
- Strong body structure with stainless steel, aluminum 6061, bronze and Delrin parts
- All electric, no water-coolant system
- Fully automatic with precision sensors
- Injection speed control for fill rate
- Electronic temperature control system
- User touch screen for operational control

TECHNICAL OVERVIEW

The APSX-PIM was created to address specific needs for designers, R&D professionals, educators, hobbyists, and low volume specialty manufacturers that weren't being met by existing small injection machines, molders and 3D prototype companies. While most of its competitors meet the need for an injection press that is portable and easy to use for one rough part at a time in a small shop or small facility, none have the repeatability and precision necessary to work with real world materials or designs. With the APSX-PIM, we set out from the beginning to create a new type of desktop injection machine – a design that combines all the attractive features of a desktop injection machine with the performance and precision of a large size fully automatic injection machine.

DESIGN ELEMENTS

**SOLID
MACHINE
WITH A
SMALL
FOOTPRINT**

The APSX-PIM isn't your ordinary manual desktop injection machine. Instead of manual injection molding actions, it's built with automated clamping, injection and eject features. Each APSX-PIM desktop injection machine employs a robust structure with steel bars, precisely designed to provide maximum mold size with a footprint that's not much bigger than a traditional manual desktop injection press. Each APSX-PIM features anodized hard aluminum blocks for a strong structure and the best scratch protection by providing superior wear resistance for a lifetime of use. All APSX-PIM are also equipped with high precision ballscrews for accuracy and rigidity of the machine.

**INJECTION
AND
CLAMPING
SYSTEMS**

The APSX-PIM features a spring powered by a precise but low-maintenance chain and ballscrew system driven by an electric motor. This mechanism provides infinite injection speed control, resulting in an injection system that is both powerful and precise at a micro level. This is much more controllable and repeatable than the underpowered injection handles on typical desktop injection presses. Along with that, state-of-the-art touchless distance sensors and nozzle valve control system provide the APSX-PIM injection plunger with exceptional flow control and moldflow profile characteristics unlike any other desktop injection machine.

APSX-PIM features a gearbox and ballscrew combo system for its clamping mechanism. This isn't an arbitrary design, but can be a flagship for clamping systems by other injection machines in the future. This means the APSX-PIM can be used in combination with other gearboxes with different gear ratios to adjust the clamping force and clamping speed, expanding tooling choices beyond the default specifications.

**INTELLIGENT
HOPPER
FEEDER**

Direct-drive motion for the hopper feeder mechanism is provided by a precision electric motor coupled with a specially designed mini screw to feed the heat barrel with plastic pellets of all kinds. This system is ideal for a repeatable and accurate material control since the system decides how much plastic is required by calculating how much is used in the previous cycles. These features make the APSX-PIM a perfect choice as a desktop injection machine.

APSX-PIM Design Considerations:

Small Size without the Compromise - a real injection machine without the typical compromises of desktop injection presses. The APSX-PIM can be moved into nearly any workbench and requires a basic 120 Volt wall outlet to operate, but has the ability to make parts with much higher quality than a rough draft prototype plastic part.

Affordable Precision and Repeatability - smaller doesn't mean less capable. The APSX-PIM uses the latest available technology for precision and repeatability. State of the art precision sensors combined with direct-drive ballscrews and a precision microstepping drive system offer superior performance compared to typical desktop injection presses.

Flowrate Control - a precise movement sensor offers the accuracy and sensitivity needed for controlling the injection amount while adjusting the plastic flowrate through the nozzle valve. This happens without restricting material choices. Any plastic including but not limited to Polycarbonate (PC), Acetal (Delrin), ABS, PC/ABS, Nylon (PA6), Polypropylene (PP), Polystyrene (PS), Polyethylene (PE), Thermoplastic Polyolefin (TPO) can be used with MFR (ASTM) > 10 g/10min or MFR (ISO) > 30 g/10min and viscosity value less than 1500 poise.

3D Printed Molds - the ability to print the molds on a high end 3D printer and use our standard 3D printed insert molds gives you much more flexibility, speed and cost reduction than any other small injection machine.

SUCCESSFULLY TESTED 3D printed mold materials:

FormLABS - High Temp Resin (semi transparent orange color)

ASIGA - FusionGRAY (solid gray color)

Stratasys – PolyJet (light green color)

MarkForged – Onyx (solid grey color)

Low Cost of Ownership - most small injection machines are more style than function, with designs that are expensive and difficult to maintain without an experienced technician. APSX-PIM is an easy-to-maintain and affordable to run desktop injection machine in both R&D labs and small manufacturing shops.

SUPPORT

As with all APSX products, APSX-PIM desktop injection machines are backed with our technical support team to ensure your satisfaction. We support your machine via email, scheduled Skype calls, phone support and with our extensive online resources, so you can be 100% sure that when you choose APSX, you've made a perfect selection.

Skype assisted help is available via calendar scheduling
2 years email support between 9AM-5PM EST.

SPARE PARTS

100% in stock for crucial parts, APSX-PIM is designed with ease of maintenance in mind. Spare parts are in stock at our Cincinnati location. All critical part orders are shipped on the same day. The machine is designed with simplicity in mind, so it is nearly maintenance free. Keep in mind APSX-PIM has no water lines, no pressured air, minimal lubrication and no routine cleaning requirements. You know what that means: No downtime at all!

LIMITED WARRANTY

(VALID ONLY IF 1 HOUR QUICK ONLINE TRAINING IS GIVEN BY
APSX LLC TEAM BEFORE THE SHIPMENT)

12 months REPAIR OR REPLACEMENT warranty condition also applies to returned machines for inspection or repair. If the QUICK ONLINE TRAINING is rejected, the warranty is VOID once the machine is shipped out- Manufacturer's liability shall be limited to repairing, replacing parts or components at the discretion of the manufacturer. Direct sales and Skype/phone support is part of the equation that allows us to provide high value at low cost. Once we determine the problem remotely via Skype, we resolve it with a replacement part or a completely new machine. You must be comfortable with general electric and mechanical repair concepts, including the appropriate safety procedures before working on your machine. If you do not have the required skills, you will need to find someone locally to assist you. Components subject to wear during normal use and over time such as metal surfaces, labels or decals, finish and condition, seals, safety gates, cabling, electric motor shafts, etc., are excluded from this warranty. Warranty of general machine tolerances is void if the machine is taken out of the crate without following the lifting directions below, disassembled or altered by customer. Manufacturer is not responsible for any damage to parts, machines, business premises or other property of the buyer, or for any other incidental or consequential damages that may be caused by a malfunction of the machine or its components.

APSX-PIM DESKTOP INJECTION MACHINE

- APSX-PIM comes in a wood crate of 50"X20'X18". Total weight is about 350 Lbs
- Unscrew the top and the front panel of the crate where the APSX LLC logo is printed
- Un-bolt the ground clamp to free the machine before lifting
- ONLY lift from the LIFT HOLES on both sides of the machine by using a lift mechanism
- The machine itself is about 250 LBS
- NEVER apply force on the RAIL that encases the wires and sensors when lifting or any other time
- NEVER hold the machine from the motors, fans or any other attached components when lifting
- If you choose not to follow these guidelines, the limited product warranty becomes void
- See the picture below as a guideline for lifting



TRANSFERABILITY

This warranty is transferable from the original end-user to another party if the machine is sold via private sale before the end of the warranty period. Should you have a problem with your machine, please consult your user manual first. If this does not resolve the problem, contact APSX through our website at www.apsx.com.

TOOLS AND ACCESSORIES

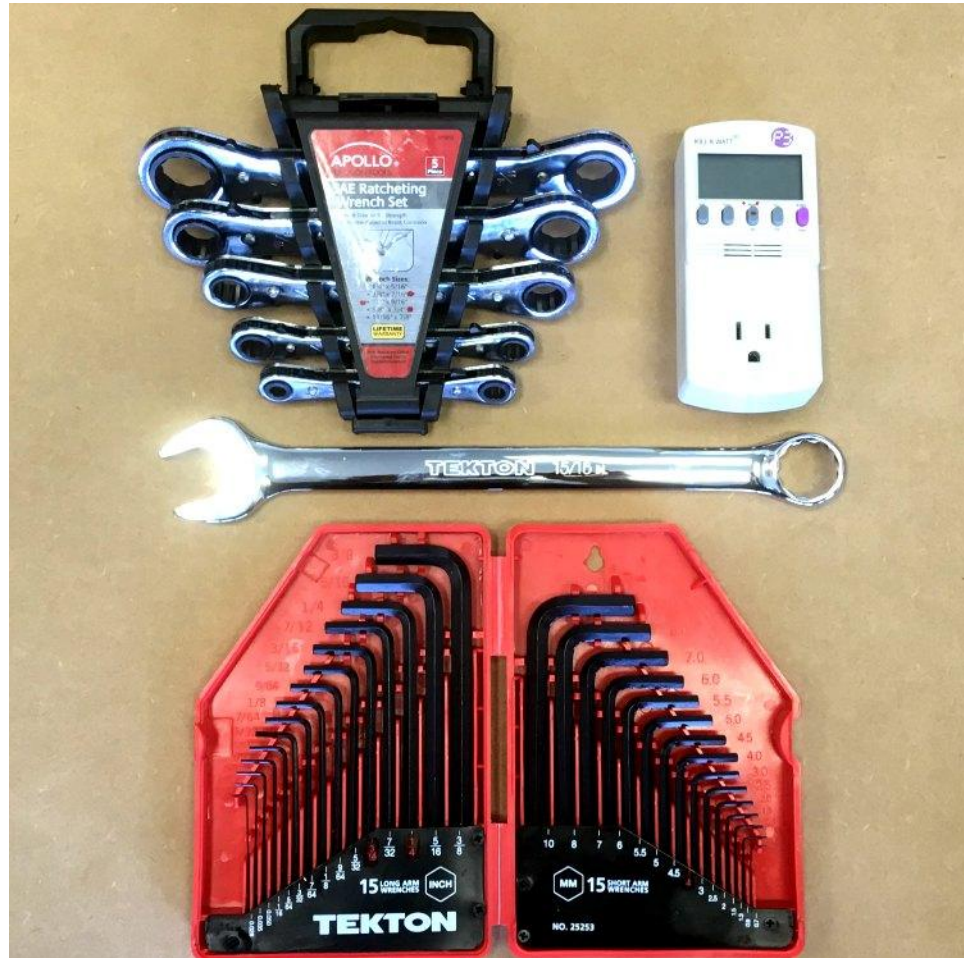

Kill-A-Watt

Kill-A-Watt meter is used to monitor the power consumption during the machine operation to ensure all the power consuming parts are in good working condition. The LCD screen shows all meter readings: Volts, Current, Watts, Frequency and Power. Press the Watt/VA key once. Watts will be displayed as the active power. Connect the Kill-A-Watt to 120V power and then to APSX-PIM power cord.

The LCD display should show the following readings for each condition below:

- SYSTEM ON: only motors are on approximately (150W)
- HEAT ON: Barrel Heater is ON until 100C approximately (900W)
- HEAT ON: Barrel Heater is ON above 100C approximately (1350W) when the set temperature is higher than current temperature.

15/16" Wrench

Use it for turning the clamp or spring ballbearings/washers manually from the sides. Simply attach the wrench to the nut on the sides next to Block 1 or Block 7

then turn manually. It can also be used to tighten or loosen these bolts if necessary by using another wrench to hold the second nut inside. These ballbearings/washers should spin against Blocks 1 and 7 freely, with a little friction by the turn of your hand. If there is no friction, or they do not spin at all, then adjust accordingly.

7/16", 1/2", 3/4" Wrenches

Use 7/16" wrench for the bolts on the hopper motor mounts. Use 1/2" wrench for the bolts on the mold clamps. Use 3/4" wrench for the bolts on the Blocks 1 and 7 that hold the 1" steel shafts in place.

3/16", 1/4" and M4 Hex Keys

Use 3/16" hex key for the bolts on the shaft collars, clamp switch collar, hopper weldment to barrel, mold fan plates, mold gates. Use 1/4" hex key for the bolts on the motor mounts to blocks and on the electronic cover. Use M4 hex key for the bolts on the band heater.

Maintenance

Due to the friction of moving parts on your machine, periodically we recommend visual inspection and lubrication of the following areas:

-Approximately every 500 hours of run time or at your best discretion-

-Apply synthetic 10W-30 oil on all areas where block bushings slide on the metal shafts, Blocks 2, 3, 5 and 6. (Use a thin even coating on metal shafts)

-Apply synthetic grease or generic chain lube to lubricate spring, clamp and valve motor chains.

-Apply synthetic grease to ballscrews on Blocks 6 and 2.